



www.orthman.com

810 - 1010
GRAIN CART
OPERATOR'S MANUAL

**ORTHMAN
MANUFACTURING
INCORPORATED**

STILL THE STRONGEST

**ORTHMAN MFG. INC.
75765 RD. 435
LEXINGTON, NE 68850**

125-008-01



WARRANTY

Orthman Mfg., Inc. warrants the whole goods products it manufactures to be free from defects in material or workmanship for a period of one (1) year from the date of sale of the product(s) to the original user. Products not manufactured, but supplied by Orthman Mfg., Inc. on Orthman products, are subject to, conform with, and are limited to the warranty of our suppliers.

Orthman Mfg., Inc. warrants the parts it manufactures to be free from defects in material or workmanship for a period of ninety (90) days from the date of delivery of the product(s) to the original user. Products not manufactured, but supplied by Orthman Mfg., Inc. on Orthman products, are subject to, conform with, and are limited to the warranty of our suppliers.

Warranty of Orthman whole goods and/or parts applies only to material and workmanship. Misuse, misapplication, neglect, alteration, accident, normal wear, or acts of God affecting Orthman products are not eligible for warranty.

Warranty of serial numbered goods will only be considered if the product has a completed Warranty Registration on file at Orthman. This Warranty Registration must be completed and returned to Orthman within thirty (30) days of the sale of the product(s) to the original user. **No serial numbered goods or related parts and/or labor will be warranted without a Warranty Registration on file.** Warranty issues falling within the first thirty days of a product's use will be handled at the discretion of Orthman. Warranty of parts will not require a Warranty Registration, but proof of date of delivery of the product to the original customer must be provided.

WARRANTY CLAIMS: A warranty claim and request to return defective product(s) must be presented to the Orthman Service Department by the selling dealer describing the defect in material or workmanship of an Orthman product(s) within ten (10) days of its discovery. This claim may be made via phone, e-mail, fax, or written request. Claims for warranty of serial numbered goods must include the Orthman product serial number and model number. Claims for warranty of parts will not require a product serial number or model number, but must be identified by an Orthman part number. Claims for warranty of whole goods or parts must also include proof of date of sale of the product to the original customer by an Orthman dealer.

The Orthman Service Department will proceed in making a preliminary decision as to the eligibility of the claim for warranty consideration. After the Orthman Service Department deems it necessary to proceed with warranty consideration, a Return Goods Authorization (RGA) will be completed by the Orthman Service Department in conjunction with the selling dealer. Upon completion of the RGA, the defective product(s) must be returned to Orthman to ensure warranty consideration. Defective product(s) must be returned to Orthman by either the selling dealer or the customer. Customer delivery of defective product(s) must be approved by Orthman and the selling dealer prior to delivery. The defective product(s) in question must be sent, freight prepaid, within sixty (60) days of the discovery of the product(s) failure and initial warranty claim. Replacement product(s) may be sent to the selling dealer, directly to the customer, or picked up at the Orthman facility. Replacement product(s), sent directly to the customer or picked up must be approved by Orthman and the selling dealer. At the discretion of the Orthman Service Department, replacement product(s) may be sent prior to, or after, the Orthman Service Department receives the defective product(s).

Any variation in the above procedure is at the sole discretion of the Orthman Service Department.

No products will be accepted at Orthman without all proper paperwork completed including Warranty Registration and RGA(s). Parts returned to Orthman without proper authorization will be returned to the sender at the sender's expense.

Orthman agrees to handle all warranty claims in a timely manner and will inform dealers of any revisions or modifications to the Orthman Warranty Policy. Eligible warranty claims will be processed by Orthman within sixty (60) days of receiving failed product(s) or a valid service or repair labor claim. Eligible warranty claims regarding returned product(s) or service and/or repair labor will be paid through a credit memo issued to the appropriate dealer's account as determined by the Orthman Service Department.

If a warranty claim is found to be ineligible for warranty coverage, the Orthman Service Department will be responsible to inform the dealer in order to determine the course of action to be taken. Orthman reserves the right to make changes in specification and design without notice and without incurring any obligations to owners of products previously sold.

TABLE OF CONTENTS

Overview.....	Section 1
Introduction.....	1-4
Warranty.....	1-5
Safety.....	1-6
Assembly.....	Section 2
Axle Assembly.....	2-2
Auger Assembly.....	2-7
Extension Assembly.....	2-10
Machine Preparation.....	Section 3
Hitch Adjustment.....	3-2
PTO Drive Instructions.....	3-3
Field Operation.....	Section 4
Safety Instructions.....	4-2
Unloading Via Auger.....	4-3
Unloading Via Pit Dump Gate.....	4-5
Lights.....	4-6
Maintenance & Lubrication.....	Section 5
Safety Instructions.....	5-2
Lubrication.....	5-2
Gearbox Maintenance.....	5-3
General Maintenance.....	5-5
Specifications.....	Section 6



INTRODUCTION



This manual details information concerning safety, operation and maintenance guide lines pertaining to your Orthman 810 Grain Cart

Read and thoroughly understand the contents of this publication before operating the grain cart. Please keep the operator's manual in good condition for handy reference in the future

This product was designed and manufactured with common sense and integrity; therefore, if the prescribed operating techniques and maintenance intervals are met, you will receive many years of excellent performance.

The directions left, right, front, and rear, as mentioned in this manual are based on the driver sitting on the tractor seat and facing in the direction of travel.

The serial number plate is located on the left, front corner tub brace. Information contained on this plate should be recorded below for future reference when ordering replacement parts from an authorized Orthman dealer, or when corresponding with ORTHMAN MANUFACTURING, INC.

Serial No. _____

SAFETY



This symbol is used to call your attention to instructions concerning your personal safety. Be sure to observe and follow these instructions.

Read this manual carefully before adjusting or operating your 810 Grain Cart



Observe all safety decals found on the Grain Cart. Replace all damaged or faded safety decals immediately, they are available at your Orthman dealer. Keep equipment clean, therefore keeping safety decals at their highest visibility level.



You are responsible for the safe operation of your Grain Cart. Anyone operating, maintaining or working around the Grain Cart must be familiar with the procedures and pertinent safety information contained in this manual.



IMPORTANT! INSTALL AND SECURE ALL SHIELDS AND GUARDS IN THE PROPER MANNER BEFORE OPERATING.



DANGER! DO NOT OPERATE GRAIN CART WITH AUGER CAGE OR PTO SHIELDS REMOVED. INJURY OR DEATH MAY RESULT.

SAFETY



DO NOT ENTER CART DURING OPERATION.
Death or serious injury may result from grain suffocation or entanglement with unloading auger.

If it is necessary to enter cart for repair or clean out, follow these steps:

1. Shut off tractor, engage park brake, and remove ignition key.
2. Wait for all moving parts to stop.
3. Open internal flow control gate.
4. Open external pit dump gate.
5. Disconnect hydraulic supply hoses from tractor.
6. Disconnect PTO shaft from tractor.



REPLACE ALL SHIELDS PRIOR TO RESUMING OPERATION.

1. Equipment is to be operated by qualified personnel only. A full understanding of the operation, maintenance, and safety requirements is mandatory before use.
2. Before operating the Grain Cart, be sure everyone is clear of the tractor and cart. Absolutely no riders on tractor or cart during operation. Severe bodily injury may result.
3. LOOK UP for obstructions before activating hydraulic auger fold.

SAFETY

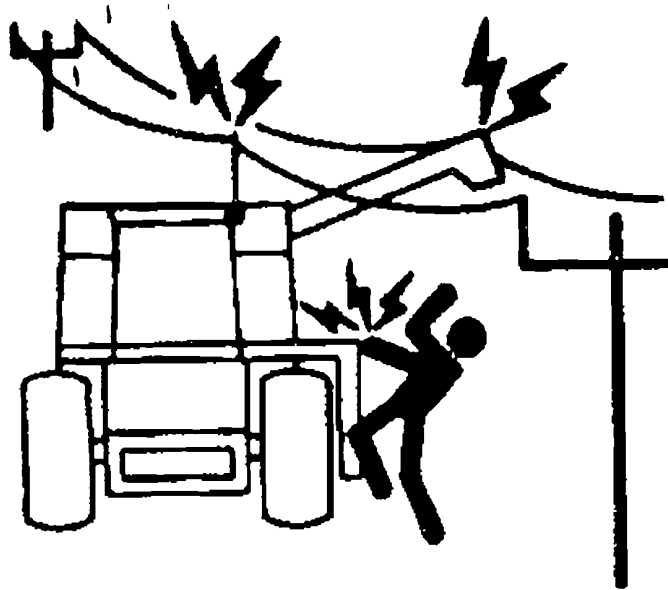

4. Stay away from overhead obstructions and power lines during setup and operation. Even without direct contact, electrocution can occur.
5. **MINIMUM** tractor horsepower requirement - 125 HP.
6. **MAXIMUM** towing speed: Loaded - 10 mph. Empty - 20 mph. Grain cart is designed for off-road use only.
7. Recommended PTO operating speed: **1000 RPM**.
8. Be sure internal flow control gate is closed before unloading auger is engaged.

SAFETY



9. Escaping hydraulic oil under pressure can have sufficient force to penetrate the skin, causing serious personal injury. Before attaching or disconnecting hydraulic lines, relieve pressure by shutting off tractor and moving corresponding remote cylinder lever in both direction. Before applying pressure, make sure all connections are tight and that lines, pipes and hoses are not damaged. Hydraulic oil escaping from a very small hole can be almost invisible. Rather than hands, use a piece of cardboard or wood to search for suspected leaks. If injured by escaping hydraulic oil, see a doctor at once. Serious infection or reaction can develop if proper medical treatment is not administered immediately.



10. Wear suitable ear protection for prolonged exposure to excessive noise.

11. Never wear ill-fitting, baggy or torn clothing when working around or on any of the drive system components.



12. Keep hands, feet, hair and clothing away from all moving or rotating parts.

13. Never operate the machine inside a closed building.

Section 2

810 Grain Cart Assembly



ASSEMBLY

Axle Assembly

The 810 Grain Cart is equipped with a rigid axle or an adjustable axle assembly which is factory installed. Note that wheel spacing can vary so be sure and check spacing before going to the field.

The adjustable axle consists of a main receiver tube and two axle hub assemblies. The width is adjustable by removing a strap securing the main receiver tube to the axle and hub assembly, sliding the axle to the desired width, and replacing the strap.

Possible width settings for this type of axle are 120" (**Note:** can not use 120" setting with 35.5 tires), 132", 144", 150" and 160" tire centers for single tires, (for 20", 22", 30", 36" 38" and 40" rows). **See Figure 2 on page 2-5**

For Kirschner straddle-row duals (available from Kirschner Wheels Inc.) the tire centers are 120" (inside dual tire center) and 180" (outside dual tire center). Duals are spaced 30" tire center to tire center. Duals are only designed to be used on 30" rows. Contact Kirschner Wheels Inc. for more information on straddle-row duals. **See Figures 1 & 2 on pages 2-4 & 2-5.**

Note: Orthman Grain Carts are sometimes sent from the factory with a special purpose shipping axle. This must be removed before field use.

ASSEMBLY

Axle Assembly (continued from previous page)

1. Jack cart frame up until wheels are clear. Block framework securely to prevent cart movement while suspended.

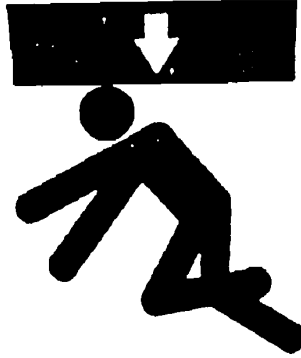

 **WARNING!:** Properly block grain cart when adjusting axle width. **DO NOT** allow anyone to position themselves underneath frame while cart is blocked up. Use safe practices to prevent needless mishaps that could result in death or permanent injury.

2. Set axle width if necessary. Use page 2-5 to determine the proper hole alignment for the desired axle width. Make sure lynch pins securing the pin or adjusting strap to the axle are replace after adjusting the axle width.

Note: If tire width settings do not correspond to those given in Figure 1 or Figure 2 the tires may not be installed correctly. See Step 3 on Page 2-6.

ASSEMBLY

Axle Assembly (continued from previous page)

For single tires

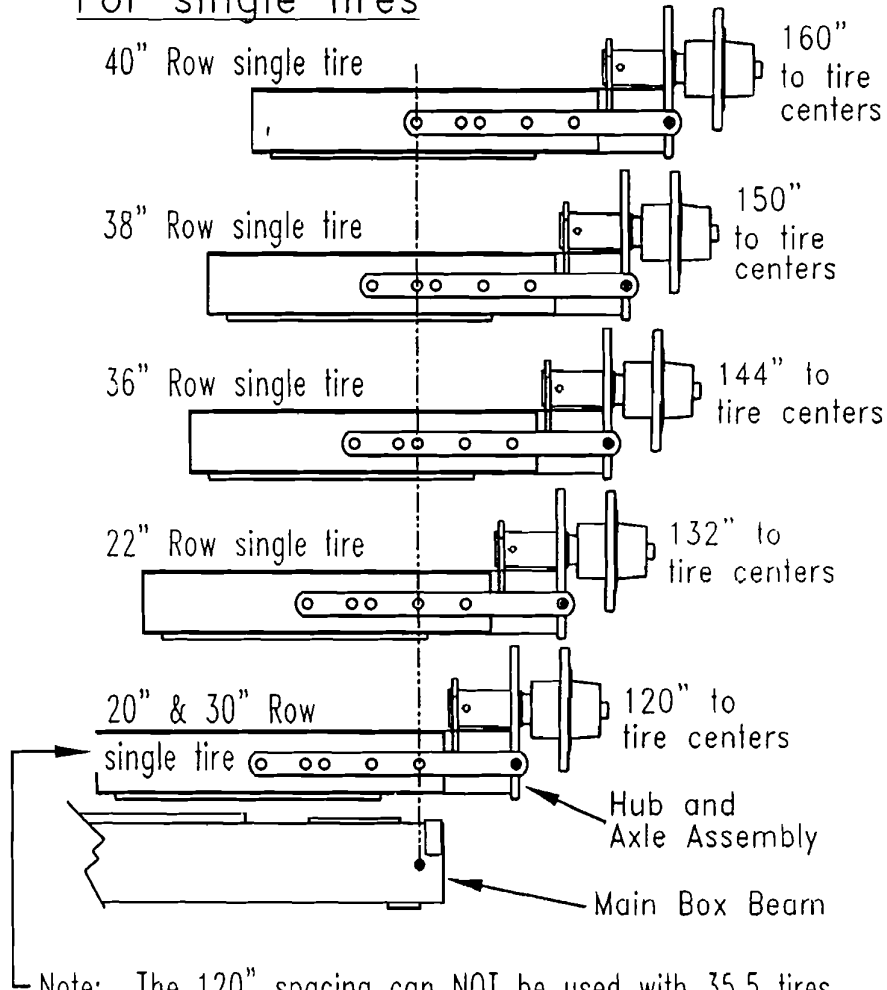

Note: The 120" spacing can NOT be used with 35.5 tires. Use the 150" spacing for 30" rows and the 160" spacing for 20" rows.

For dual tires (30" spacing)

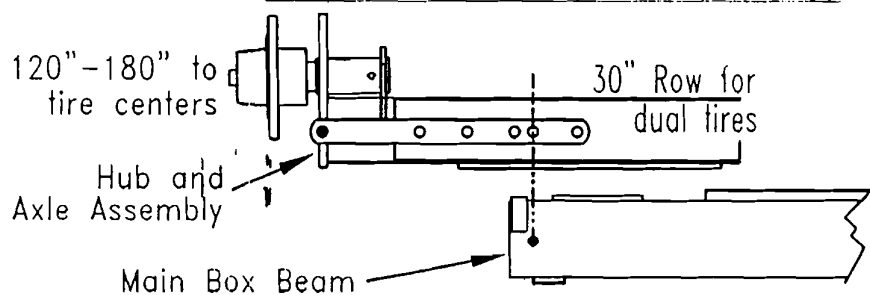

ASSEMBLY

Axle Assembly (continued from previous page)

3. Mount wheels onto hubs with wide side of rim (1 1/2" offset) in towards cart axle. For proper placement of nuts see Figure 3 below. Torque to 340 lb-ft. Check torque after first hour of operation and weekly thereafter.

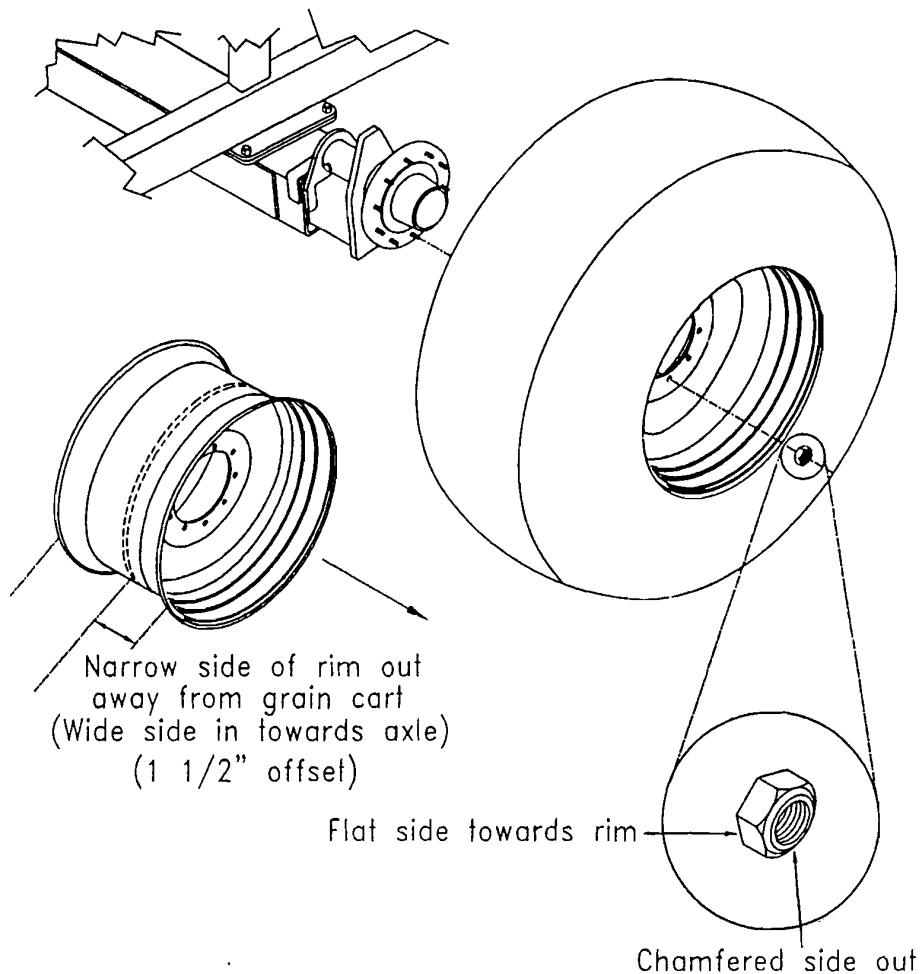

FIGURE 3

4. Carefully remove support blocks and lower cart to ground.

ASSEMBLY

Auger Assembly



IMPORTANT! The auger/tube clearance has been set at the factory, but it is necessary that this be checked before initial installation and whenever the auger is disassembled for repair.

The auger shaft (#1) must be 1/8" inside the outer surface of the hinge plate (#2). See below. Use a framing square to measure this. To adjust clearance, loosen the end bearing lock collar (#3), by loosening socket head screw and rotating the collar. Use a hammer and punch to loosen and retighten lock collar. Move the auger for the proper 1/8" clearance, and then rotate lock collar tight. Check clearance again, and if correct, tighten the socket head set screw.

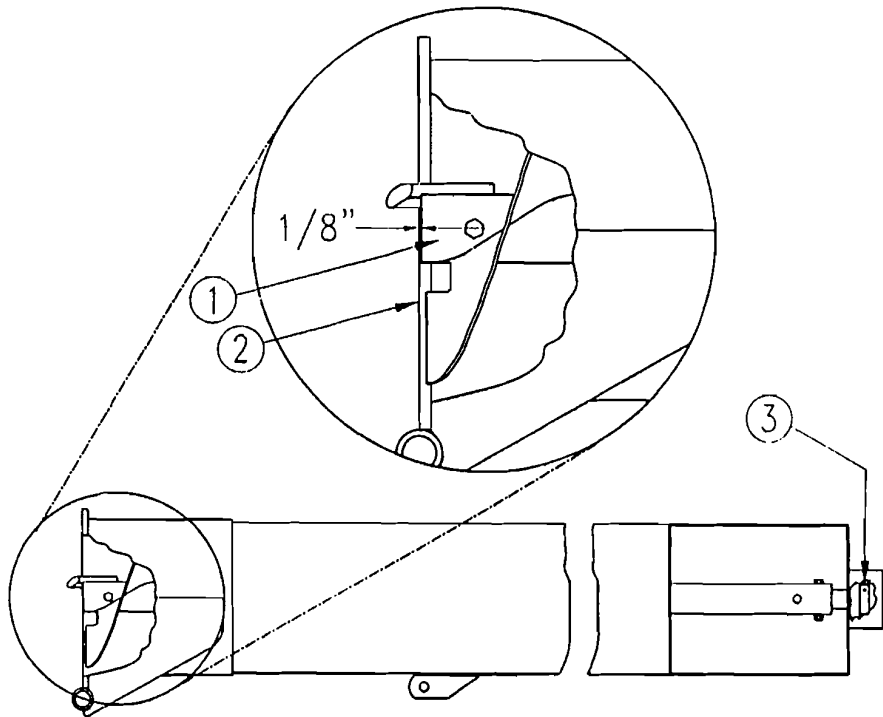

FIGURE 4

NOTE! The end of the rubber auger discharge boot is tucked inside the tube and fastened in place for shipment. Before operation, cut binding and pull discharge boot out to prevent damage.

ASSEMBLY

Auger Assembly (continued from previous page)

1. Position auger rest onto outside left rear corner of grain cart tub with four $3/8"$ x $1\frac{1}{4}"$ carriage bolts (A). Secure assembly with $3/8"$ lock washers (B) and $3/8"$ nuts (C). See Figure 5 below.

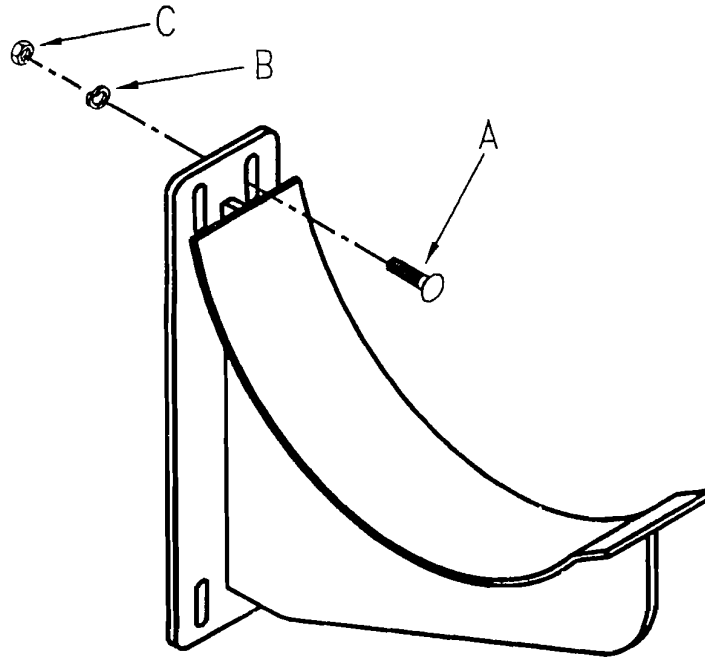

FIGURE 5

ASSEMBLY

Auger Assembly (continued from previous page)

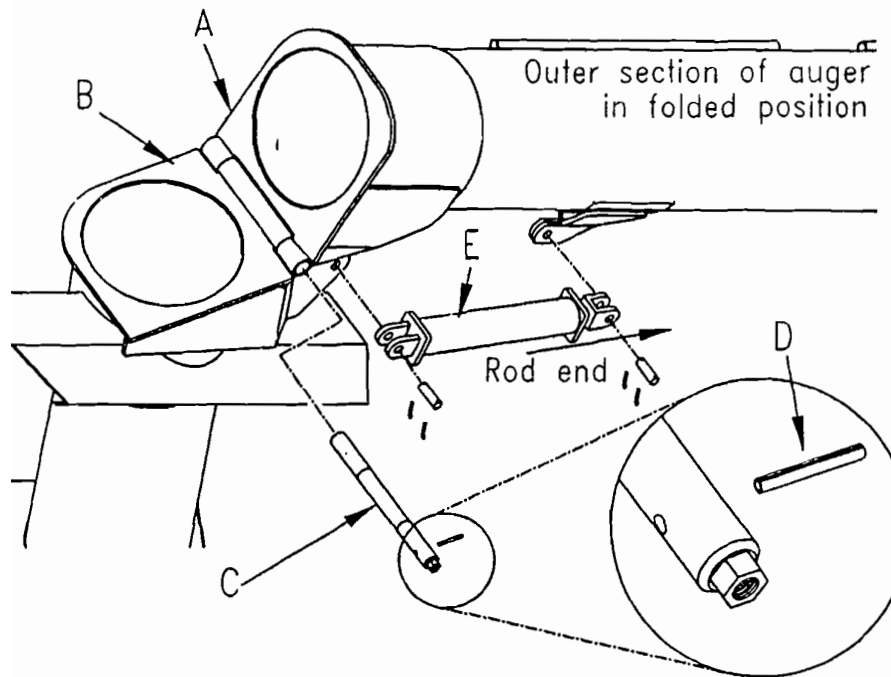

FIGURE 6

2. Place discharge auger assembly up on the grain cart in the transport (folded) position. See Figure 6. Align plate (A) with bottom auger plate (B). Grease hinge pin (C) and insert into hinge tube with welded nut end on the bottom as shown. This nut is important for pin extraction when the auger must be removed. Drive the pin with a rubber mallet or other means so as not to damage the nut.

3. Align the hole through hinge pin and hinge tube. Drive $\frac{1}{2}$ " x $2 \frac{1}{2}$ " roll pin (D) in place, securing the hinge assembly. See Figure 6.

4. Install butt end of 3"x 18" hydraulic cylinder (E) to mount on the bottom auger as shown, using the pin provided. Fasten with cotter keys. Connect hydraulic hoses to cylinder fittings, and cycle the cylinder several times to remove air from the system. Carefully extending the rod end of the cylinder to align mounting holes to the upper auger tube mount. Connect and secure with pin and cotter keys.

Extension Assembly

Refer to page 2-11 for 810 extension diagram.

1. Position left extension panels #1, #2 and #3 in place on auger side of tub with 5/16 x 3/4 carriage bolts and flange nuts. Insert bolts from bottom up through tub and extension mounting surfaces. Attach these 3 panels to each other with the same 5/16 x 3/4 carriage bolts and flange nuts.

NOTE: Limit number of bolts secured initially to enable alignment with other extension members and corner braces.

2. Place front panels #6 and #7 and rear panels #4 and #5 in similar manner as step #1.

3. Align corner braces #14 in corners at left front and left rear. Fasten with 5/16 x 3/4 carriage bolts from outside inward.

4. Loosely connect mounting brackets #15 on front and back right side in similar manner to previous steps.

5. Assemble splash board sections #8, #9 and #10 before lifting up to cart.

6. Attach splash board to #15 mounting brackets, and use #16 brace to brace center of splash board.

7. Attach support tube #13 to cross member of grain tank with plates #26, 3/8 x 6" carriage bolts, flat washers, lock washers and nuts. Leave these bolts loose until all support braces are installed.

8. Attach support tube #12 to ears between front and back extensions and brace support tube #13 with 1/2 x 2 1/2" bolts and lock nuts.

9. Attach support straps #11 on left side between extension sections and tank cross members with 1/2 x 1 1/2" bolts and lock nuts.

10. Insert all carriage bolts, flange nuts in the remaining holes in the extension panels. Position all extension members and panels so as to eliminate gaps, and then tighten all nuts on extension members and all nuts on the support braces.

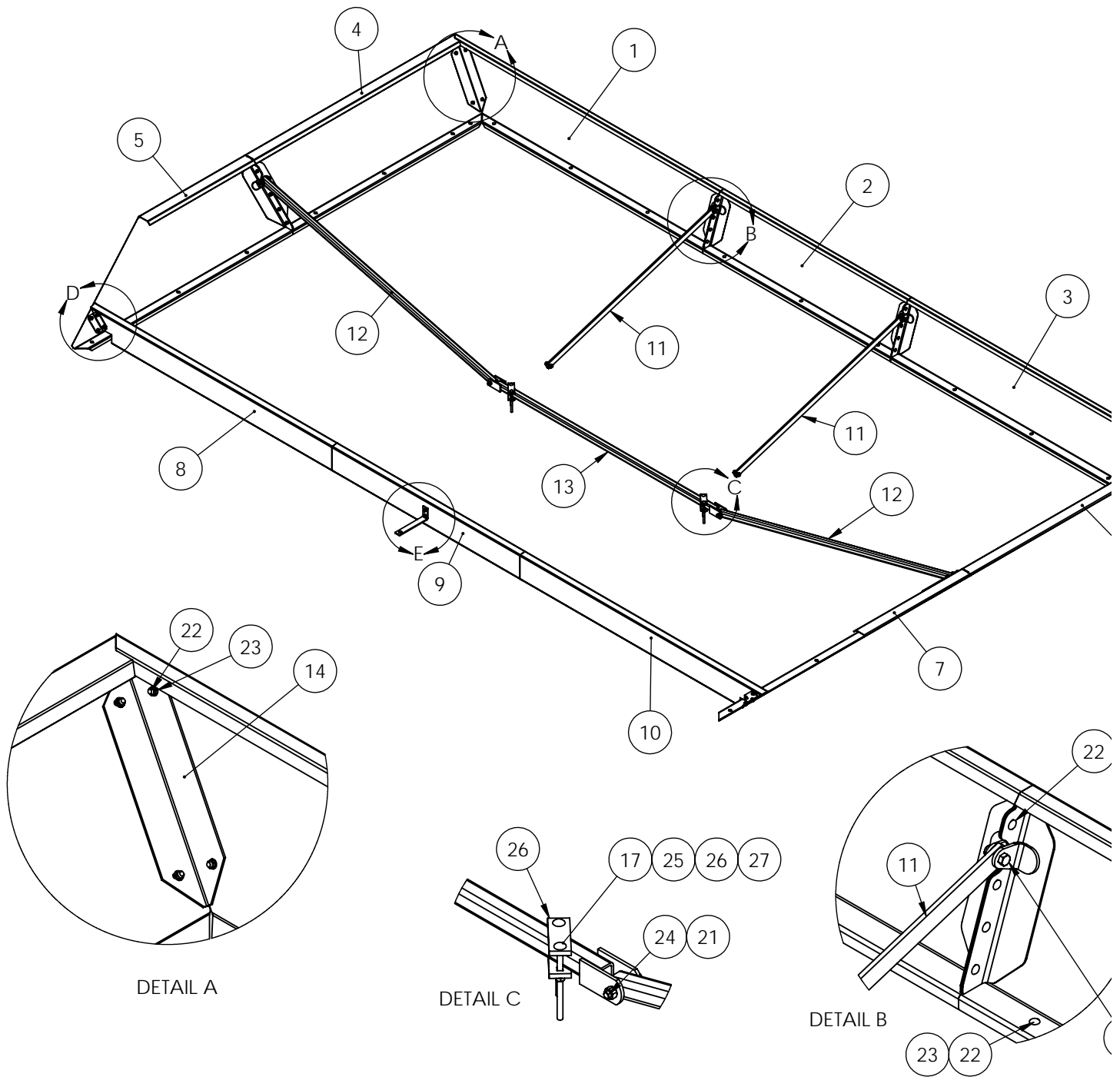

DETAIL A

DETAIL C

DETAIL B

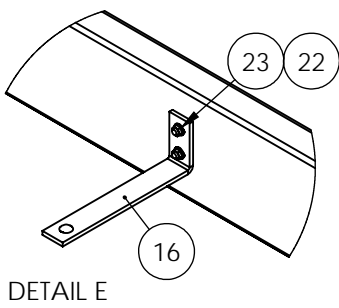

DETAIL E

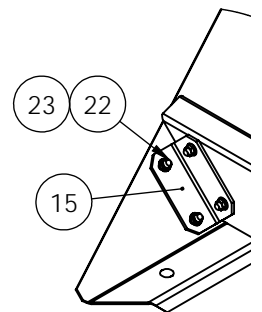

DETAIL

ITEM NO.	QTY.	PART NO.	ITEM NO.	QTY.	PART NO.
1	1	320-587	14	2	320-409
2	1	320-585	15	2	320-402
3	1	320-589	16	1	320-411
4	1	320-591	17	4	100-074
5	1	320-593	18	4	108-007
6	1	320-595	19	4	108-018
7	1	320-597	20	4	102-005
8	1	320-603	21	8	102-028
9	1	320-599	22	64	100-002
10	1	320-601	23	64	102-113
11	2	320-445	24	4	100-121
12	2	320-417	25	4	100-116
13	1	320-426	26	4	320-427

Section 3

810 Grain Cart Machine Preparation



MACHINE PREPARATION

The following procedure will help the operator properly prepare the tractor and grain cart for use.

Hitch Adjustments:

1. Adjust tractor drawbar according to standard ASAE specifications for 1 3/8"-21 spline or 1 3/4"-20 spline 1000 rpm PTO drive. Dimension guidelines are given in the figure below. Align drawbar with center line of PTO drive and secure from side movement.

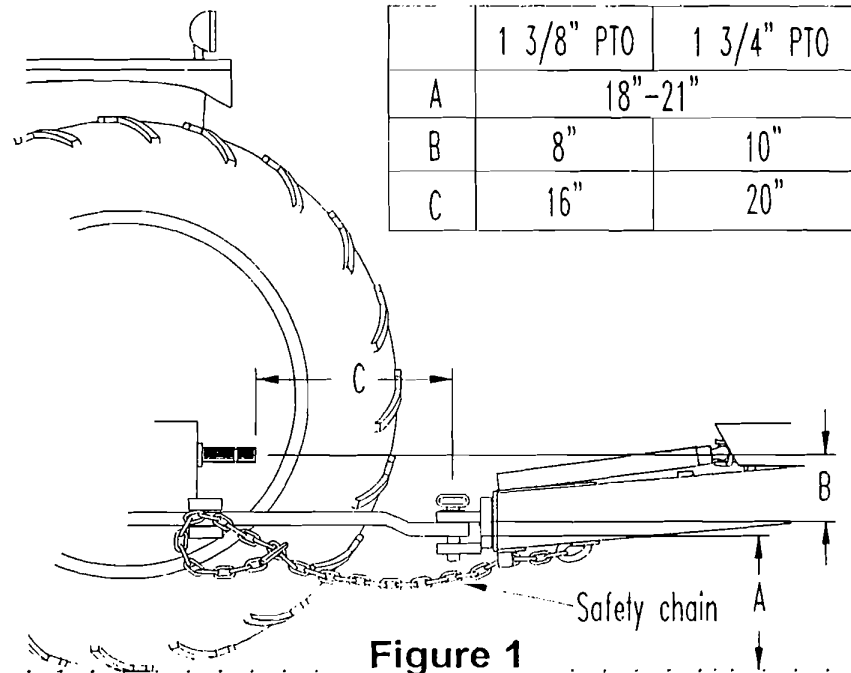

Figure 1



WARNING! Clear the area of all bystanders, especially children, before attaching tractor to grain cart to tractor. Serious injury or death may result from tractor run over.

NOTE: Some tractors with clevis hitch may require a different tongue on the Orthman Grain Cart to accommodate them. Also tractor drawbars equipped with a hammer head pin may interfere with the PTO shaft. Contact your Tractor dealer for the correct drawbar configuration if this problem arises. Different Grain Cart tongues are available from your Orthman MFG. dealer.

Single tab tongue

318-579 for non-scale cart

318-624 for scale cart

Clevis type tongue

318-330 for non-scale cart

318-628 for scale cart

MACHINE PREPARATION

2. Connect the grain cart to tractor with 1 3/8" x 7 1/2" drawbar pin. Secure pin with supplied linch pin.

NOTE: Always attach safety chain to tractor, not to the drawbar, when hooking to the grain cart

3. Orthman MFG. Grain Carts are available with either 1 3/8" - 21 spline (part number 152-189) or 1 3/4" - 20 spline (part number 152-187) 1000 rpm PTO drive shaft yokes. If yours Grain cart PTO shaft does not match the tractor PTO shaft, contact your Orthman MFG. dealer to obtain the correct size.



IMPORTANT! Check drive shaft U-joint angles. If excessive, readjust drawbar height accordingly. Swivel hitch on cart can be turned 180 degrees to either raise or lower tongue approximately 2".

4. The hoses on the Grain Cart have been color coded into pairs. The green pair control the folding of the auger and the red pair control the flow gate over the auger inside the cart. When connecting the ISO tipped hoses into the tractor remote outlet, match the symbol on each Hydra-Grip® with the symbol on the tractor remote outlet. This arrangement should produce a natural motion for the operator.

5. Lubricate grain cart and check fluid levels per the lubrication and maintenance **Section 5** of this manual. Check tire inflation pressure and lug nut torque prior to each use period. Torque and tire pressure recommendations are on page 5-4.

PTO SHAFT INSTRUCTIONS

The grain cart is equipped with a friction disc slip clutch and an overrunning clutch to protect the gear box and auger from overloading and shock loads.

Before operating the cart initially or after the cart has been in storage for one season or longer the following is recommended to prepare the clutch for field operation. A 1/2 inch socket, ratchet, and torque wrench will be needed.

1. Make sure that the tractor is off and the PTO is disengaged.

MACHINE PREPARATION

2. Disconnect the driveline from the tractor.
3. Locate the six bolts that hold the clutch pak together. These will be the six bolts that form a ring on the outside of the clutch. Loosen each bolt until it is finger tight and then tighten each bolt one half turn.
4. Reconnect driveline to tractor. Making sure that grain cart is attached to tractor with hitch pin.
5. Start the tractor. Engage the PTO and run for a few seconds, or until clutch visibly smokes.
6. Shut off PTO. Shut off tractor engine and disconnect grain cart driveline from tractor.

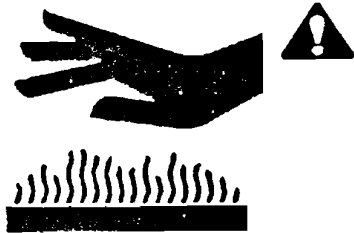

**CAUTION: CLUTCH MAY
BE HOT AFTER
OPERATING!**

7. Tighten the six bolts that were loosened in step 3. Tighten the bolts until the compression plate at the rear of the clutch is pulled into contact with the main clutch housing. Then torque each bolt to 30 ft-lbs.
8. Locate the four bolts that attach the clutch to the driveshaft. Check to see that each bolt is torqued to 30 ft-lbs.
9. Check the operation of the overrunning clutch using one of the following methods Method 1: With the tractor shut off and the key removed from the ignition, connect the grain cart driveline to the PTO. Try and rotate the shaft at the gearbox. It should be solid in one direction and be able to rotate in the other direction. Method 2: Connect the graincart driveline to the tractor and run the grain cart at low speed while it is empty. When the PTO is disengaged the auger should continue to rotate after the PTO has stopped.

Section 4

810 Grain Cart

Field Operation



FIELD OPERATION

As the operator it is crucial that you understand and follow these procedures. They must be followed to obtain optimum performance and reliability from your grain cart. Please read and practice the following recommendations and procedures concerning operation of the cart and your personal safety, both in and out of the field. Keep this manual convenient for reference at anytime.



CAUTION! Equipment is to be operated by qualified personnel only. A full understanding of the operation, maintenance and safety requirements is mandatory before use.



CAUTION! Before operating grain car, be sure everyone is clear of tractor and cart. Absolutely no riders on tractor or cart during operation. Severe bodily injury may result.



CAUTION! Do not exceed 10 mph when loaded. Avoid ruts, washouts, pivot tracks, etc.. at high speeds. If rough conditions are inevitable, throttle back and gear down to acceptable speed while crossing such conditions.



CAUTION! Look up for obstructions before activating hydraulic auger fold. Make sure auger is fully extended before unloading.

Lubricate cart according to intervals indicated in Section 5 of this manual.

FIELD OPERATION

UNLOADING VIA AUGER

1. Unfold (extend) auger to unloading position.
2. Engage PTO with tractor at an idle (Be certain internal gate is closed and auger is empty).

 **IMPORTANT! DO NOT** engage PTO lever at high engine RPM's. Severe drive-line damage may occur, resulting in extended down time and expensive repair costs. Take time to idle down engine. After engaging PTO throttle engine up to desired unloading speed. Recommended PTO operating RPM is 1000. **DO NOT exceed 1000 RPM.**

3. Slowly open internal flow control gate until indicator is positioned into open range.
4. When grain flow slows, gradually close internal flow control gate until rooster tailing of grain does not occur. A window is provided to enable you to see when the grain begins to rooster tail.
5. When grain tank is satisfactorily empty, shut internal flow control gate, throttle back engine, and disengage PTO lever.
6. If auger needs to be shut down before tank is empty, shut internal flow control gate and empty auger before disengaging PTO.

DO NOT START OR STOP UNLOADING AUGER FULL OF GRAIN UNLESS ABSOLUTELY NECESSARY FOR SAFETY REASONS.

FIELD OPERATION

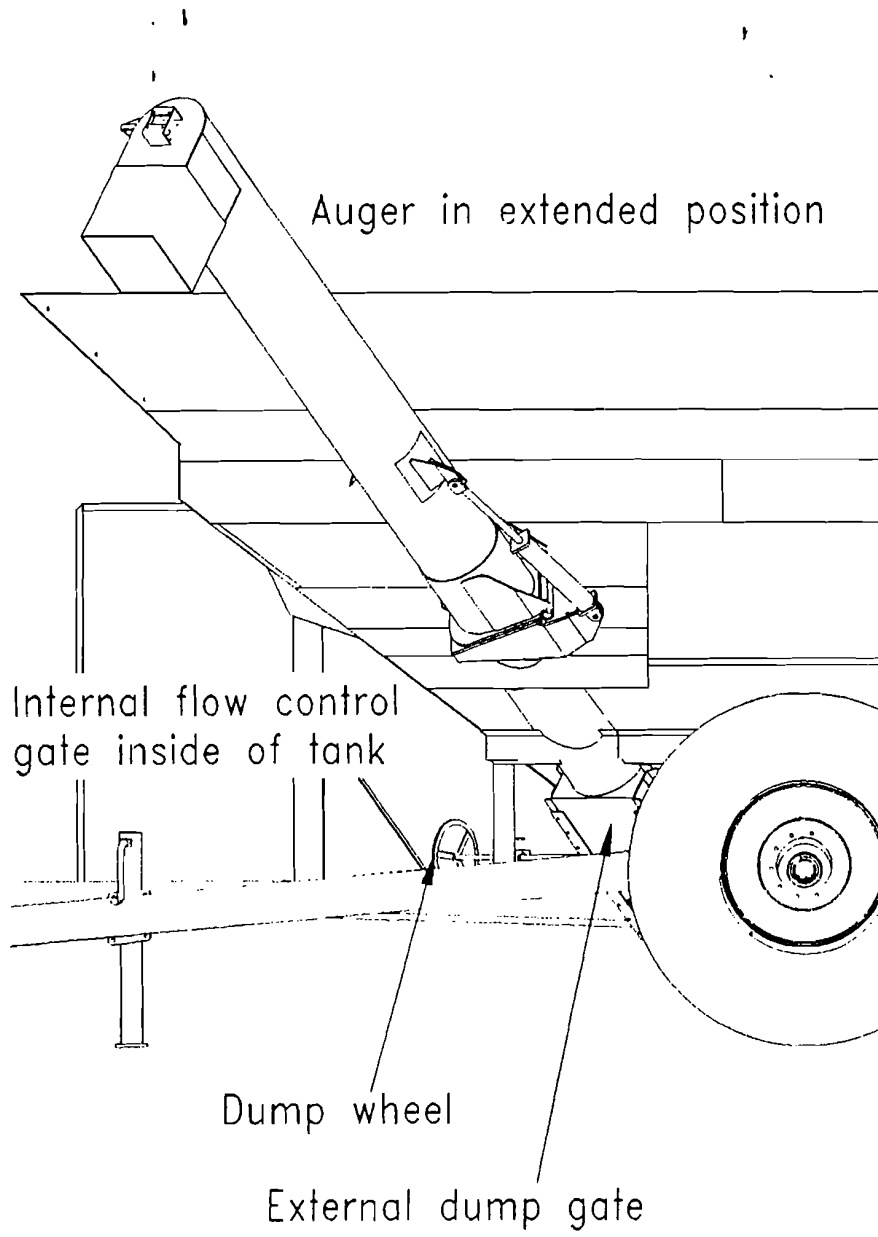

FIELD OPERATION

UNLOADING VIA PIT DUMP GATE



⚠ WARNING!: To prevent unintentional tractor movement while operating the dump gate, engage park brake, shut off tractor, and remove keys from ignition.

NOTE: Always attach safety chain to tractor, not to the drawbar, when hooking to the grain cart.

1. Position the grain cart over the desired unloading zone. Activate the internal flow gate to the “open” range. Do not engage the unloading auger. Shut off the tractor and engage the parking brake. Remove keys from the ignition.
2. Rotate the pit dump wheel to open the gate, initiating grain flow out of the cart. The sprocket latch enables the gate to be held in the desired position. If flow reduction is required the sprocket latch must be manually released and the wheel rotation reversed.
3. When the cart is empty close the external pit dump gate and the internal flow control gate.

FIELD OPERATION

Lights:

Taillights include turn signals lights, brake lights, and flashers. A working light is mounted to the outer end of the auger. Lights are factory installed with a universal connection to plug into the tractor light outlet.

NOTE. Check all lights occasionally to make sure they are all operational.

The auger light is a 5" sealed beam (GE H7610)

The amber taillight has a single element bulb (CEC1156)

The red taillights has a dual element bulb (CEC1157)

The auger light cable is routed along the auger to the auger hinge and down the left side of the tank. This wire should be checked occasionally to assure it doesn't come loose and get snagged or pinched when the auger is folded or extended. Taillight wires should also be checked occasionally for snagged or broken cables.

1	Black	Ground
2	Green	Field light
3	Yellow	Left hand turn signal
4	Not used	Not used
5	Blue	Right hand turn signal
6	Red-Brown	Tail light
7	Not used	Not used

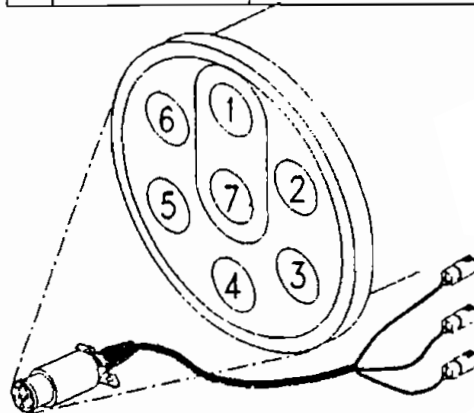

Section 5

810 Grain Cart

Maintenance and Lubrication



MAINTENANCE & LUBRICATION

SAFETY:

To safely prepare cart for service, please follow these steps.

1. Shut off tractor, engage parking brake, and remove key from ignition.
2. Disconnect PTO shaft from tractor.
3. Disconnect hydraulic supply hoses from tractor.
4. Visually inspect machine to ensure all shields are attached to their respective positions. This is to protect you and others from needless accidents!

LUBRICATION:

The recommended lubrication intervals, if properly followed, should result in continued satisfactory grain cart performance. Intervals cited below are based on average machine working conditions. If working in extreme conditions, exposed components should be lubricated more frequently.

 **WARNING! DO NOT service grain cart when PTO shaft or hydraulic hoses are connected to tractor.** Accidental entanglement with driveline or auger could result in death or permanent injury.

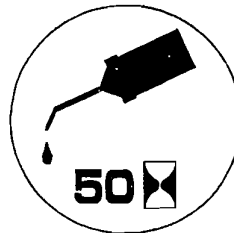
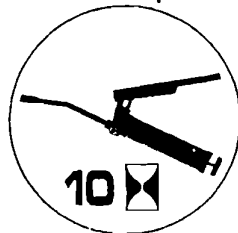

The left symbol indicates component should be lubricated with a multipurpose lithium based NLGI NO. 2 grease at recommended hourly intervals indicated within the circle (i.e. every 10 hours of operation).

The symbol on the right indicates component should be lubricated (level checked) with an SAE 90 gear oil with an extreme pressure additive at recommended hourly interval within the circle (i.e. gearbox level should be checked every 50 hours of operation).

MAINTENANCE & LUBRICATION

SAFETY:

To safely prepare cart for service, please follow these steps.

1. Shut off tractor, engage parking brake, and remove key from ignition.
2. Disconnect PTO shaft from tractor.
3. Disconnect hydraulic supply hoses from tractor.
4. Visually inspect machine to ensure all shields are attached to their respective positions. This is to protect you and others from needless accidents!

LUBRICATION:

The recommended lubrication intervals, if properly followed, should result in continued satisfactory grain cart performance. Intervals cited below are based on average machine working conditions. If working in extreme conditions, exposed components should be lubricated more frequently.



WARNING! DO NOT service grain cart when PTO shaft or hydraulic hoses are connected to tractor. Accidental entanglement with driveline or auger could result in death or permanent injury.

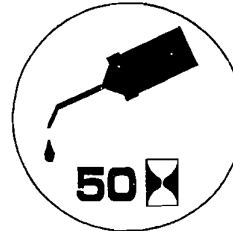
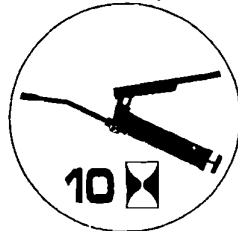

The left symbol indicates component should be lubricated with a multipurpose lithium based NLGI NO. 2 grease at recommended hourly intervals indicated within the circle (i.e. every 10 hours of operation).

The symbol on the right indicates component should be lubricated (level checked) with an SAE 90 gear oil with an extreme pressure additive at recommended hourly interval within the circle (i.e. gearbox level should be checked every 50 hours of operation).

MAINTENANCE & LUBRICATION

GEARBOX:

The drive line gearbox should be visually inspected daily for possible seepage or loss of gear oil. If a leak develops, keep a close watch on gearbox fluid levels until problem can be corrected. Under normal conditions, the gearbox level should be checked in 50 hour intervals (about every two weeks) according to the following procedure.

1. Position cart on level, shut off tractor and engage park brake.
2. Remove fill plug on top of gearbox. Fluid level should be up to the top of the fill plug. If low, slowly add SAE 90 gear oil. **Do not overfill.** (See Figure 1 below and Figure 2 on page 5-4.)

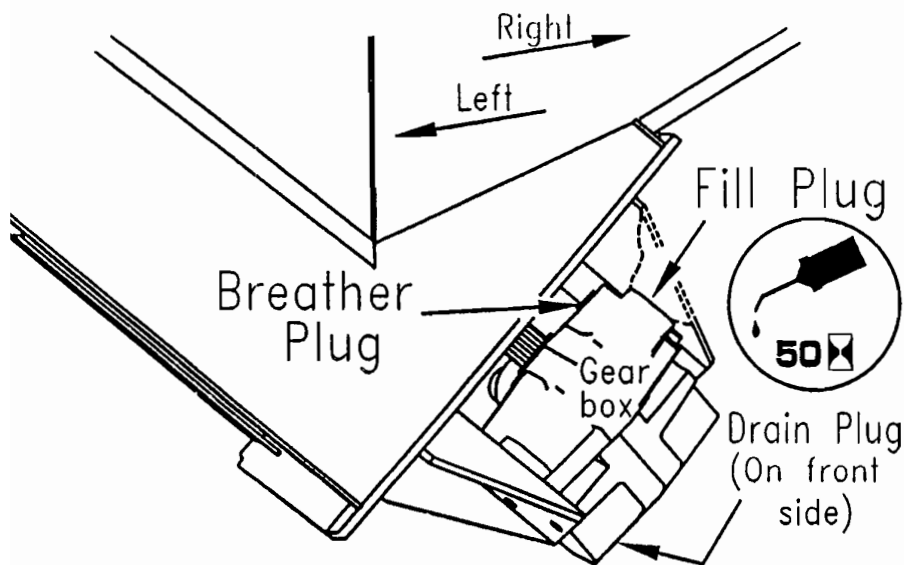

**Rear view
Figure 1**

3. Replace plugs to their respective locations and wipe excess oil from gearbox surface.

Please refer to the following page for Figure 2 and for step 4 of the instructions.

MAINTENANCE & LUBRICATION

Gearbox: (continued from previous page)

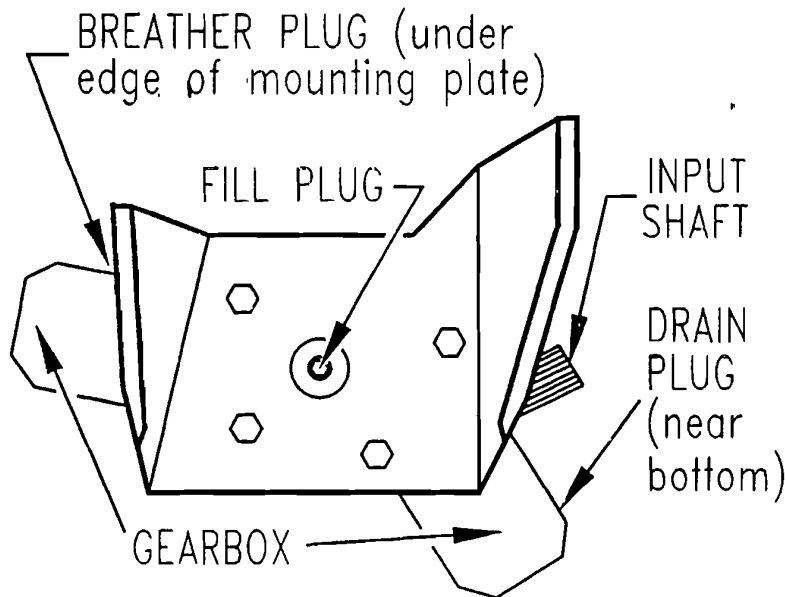

**Viewed from Top of Gearbox
(On Right Hand Side of Cart)**

Figure 2

4. Check breather plug for build-up of mud or dirt and clean if necessary. This allows the gear oil to expand and contract with temperature changes.

MAINTENANCE & LUBRICATION

OIL CHANGE:

Change at beginning of each use season.

1. Remove the drain (bottom) plug and drain oil from gearbox. A suction pump may be required in some cases to completely drain gearbox. See Figure 1 on page 5-3 and Figure 2 on page 5-4.
2. Inspect oil for indications of foreign material.
3. If no contaminants are found, refill with approximately 26 fl. oz. of an extreme pressure SAE 90 weight gear oil until level is up to fill plug. If contaminants are found in the gearbox, remove gearbox and disassemble to locate and replace worn parts.

GENERAL MAINTENANCE:

The following tips will extend the useful machine life. A few minutes taken at the beginning and end of each season may add years of serviceable life to the machine.

Beginning of Use Season.

1. Drain gearbox oil and refill. Winter condensation may have caused formation of water in gearbox. See procedure above.
2. Visually inspect U-joints, bearings, hubs, cylinders, etc. for wear and replace as needed.
3. Check wheel bearings. If necessary, pack or replace wheel bearings.
4. Check lug nut torque and tire inflation pressure recommendations, (see page 5-6).
5. Grease all grain cart grease zerks (see page 5-7). Do NOT forget to pull front half of PTO shaft out almost all of the way and grease the zerk that allows the PTO halves to slide together.
6. Inspect hitch pin and replace if worn.

MAINTENANCE & LUBRICATION

During Use Season.

1. Check lug nut torque weekly (340 lb-ft.).
2. Check tire inflation pressure frequently.

24.5 x 32 16ply - 39psi
30.5 x 32 12ply - 35psi

3. Lubrication:

A. Lubricate auger bearings and drive shaft carrier bearings every 50 hours or as needed. An approximate interval would be twice during the use season.

IMPORTANT! Do not grease grain cart bearings excessively, they are sealed bearings that are factory lubricated. If over greased, seal damage may occur, leading to premature bearing failure.

B. Lubricate the PTO shaft where the front half slides into the rear half. The front half of the PTO shaft will have to be pulled out almost all of the way until the access hole becomes visible. Rotate the shield until the grease zerk becomes visible. Note: The drive line can also be rotated freely in one direction to make the zerk more accessible.

C. Lubricate U-joints in drive line every 10 hours.

Note: On drive line U-joint yoke located near gearbox input shaft, the lock pin has intentionally been removed allowing yoke to slide on gearbox spline, relieving drive line strain due to possible frame flex.

Also note that Grain Carts use a constant velocity type of U-Joint which has two grease zerks on it.

D. Lubricate auger hinge every 50 hours.

E. Lubricate internal flow control slide with graphite weekly.

4. Check gearbox oil level biweekly or every 50 hours.
5. Inspect hydraulic cylinders and lines frequently for leaks.

MAINTENANCE & LUBRICATION

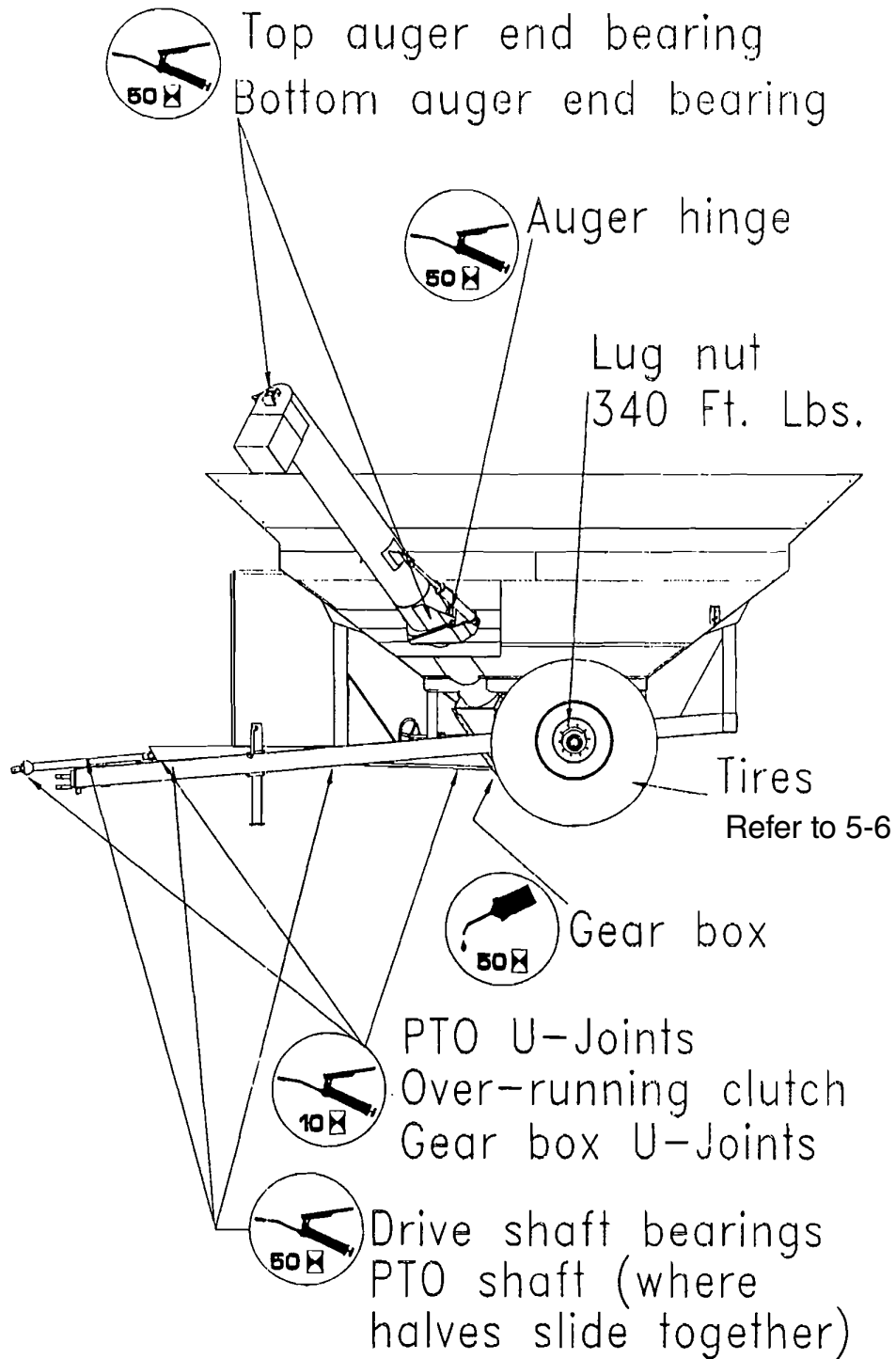

Figure 4

Section 6

810 Grain Cart Specifications



Specifications

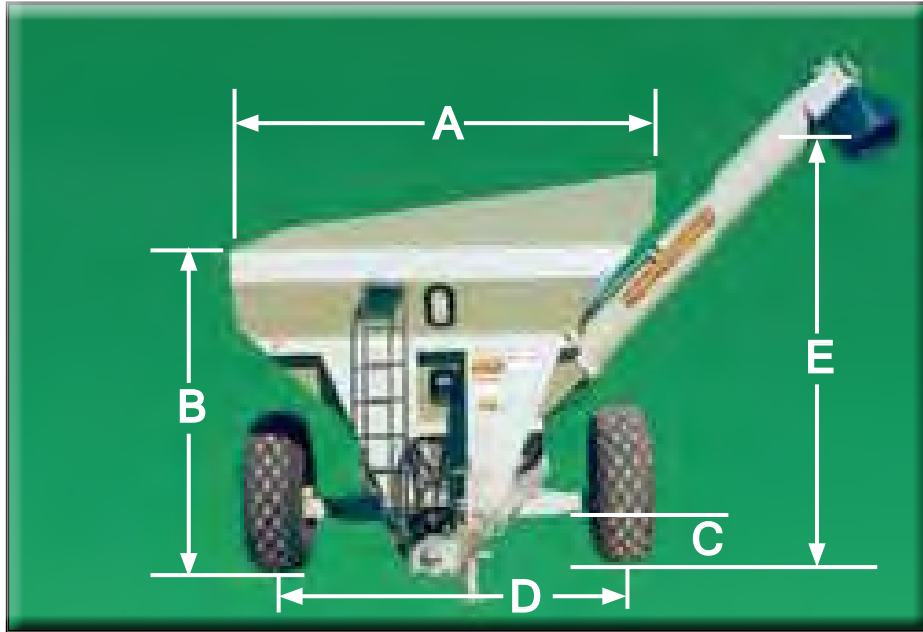

SPECIFICATIONS

810 SCOUT

Capacity	840 bu.
A (width)	142"
B (left side height)	120"
C (axle clearance)	16.5"
E (auger clearance)	151"
Overall Length	314"
Length of Tank	216"
Extension Length	244"
Drawbar Length from Axle	218"
Tongue Height	18" - 21"
Tank Material	11 gauge
Hydraulic Hose	1/4" and 3/8"
Windows	front and rear
Lights	tail and auger
Slip Clutch	15,000 in.lb.
Override Clutch	standard
Gearbox Oil Capacity	2 pints
Loaded Tongue Weight	5950 lb.

Torque Specifications

RECOMMENDED DRY BOLT TORQUE

SAE GRADE 5

Bolt Size	ft. - lb.
3/8	32
7/16	52
1/2	80
9/16	115
5/8	160
3/4	280
7/8	455
1	680
1 1/8	850
1 1/4	1200

SAE GRADE 8

Bolt Size	ft. - lb.
3/8	36
7/16	59
1/2	88
9/16	130
5/8	175
3/4	315
7/8	510
1	760
1 1/8	1075
1 1/4	1500